

D Ersatzteilliste	Motorsense	106LR 106BR	Inhaltsverzeichnis	Seite
			Kurbelgehäuse, Kurbelwelle, Kolben Vergaser, Ventilsteuerung Starter, Tankhalter, Kraftstofftank Luftfilter, Auspuff Lüfterrad, Zündspule, Kupplung Zylinderabdeckung Schaftrrohr, Schutz Gasbetätigung, Griff 106LR Gasbetätigung, Griff 106BR Werkzeug, Zubehör Ersatzteile, Bestell-Richtlinien	2 3 4 5 6 7 8 9 10 11 12
GB Spare parts list	Brushcutter	106LR 106BR	Table of contents	Page
			Crank case, crankshaft, piston Carburetor, exhaust-, intake valve Recoil starter, tank guard, fuel tank Air cleaner, exhaust Flywheel, coil, clutch Cover cylinder Shaft, protection Throttle control, handle 106LR Double handle, throttle control 106BR Tools, accessories Spare parts, directions for ordering	2 3 4 5 6 7 8 9 10 11 12
F Liste de pièces de rechange	Debroussailleuses	106LR 106BR	Table des matières	Page
			Carter de manivelle, vilebrequin, piston Carburateur, valve échappement & admission Lanceur, protection réservoir, réservoir d'essence Filtre à air, échappement Turbine, bobine, embrayage Capôt cylindre Tube de transmission, protège lame Lever régulateur, guidon 106LR Poignée guidon, levier régulateur 106BR Outillage, accessoires Pièces de rechange, directives pour les commandes	2 3 4 5 6 7 8 9 10 11 12
E Lista de piezas de recambio	Desbrozadora	106LR 106BR	Indice	Página
			Carter cigüenal, cigüenal, piston Carburador, valvula Arranque, deposito de gasolina Filtro de aire, escape Turbina, bobina, embrague Cubierta Tubo, proteccion Acelerador de gas, empuñadura 106LR Tubo, acelerador de gas 106BR Herramientas, accesorios Piezas de recambio, directivas de pedido	2 3 4 5 6 7 8 9 10 11 12



Bild-Nr. Pos.-No. Pos.-No.	Bestell-Nr. Order-No. No. de Cde Ref.-Nr.	Modell Type Modelo Modelo	Menge Quantity Nombres Cantidad	Kurbelgehäuse, Kurbelwelle, Kolben	Crank case, crankshaft, piston	Carter de manivelle, vilebrequin, piston	Carter cigüenal, cigüenal, piston
1	592-10050-01		1	Zylinderblock	Cylinder block set	Cylindre	Cilindro
5	592-15005-02		1	Abdeckung	Cover, camgear	Couvercle	Cubierta
6	592-10040-01		1	Abdeckung	Rocker cover compl	Couvercle	Cubierta
7	592-15007-00		1	Dichtung	Gasket, cover camgear	Joint	Junta
8	592-15008-00		1	Dichtung	Gasket, rocker cover	Joint	Junta
10	592-15010-00		1	Ventil	Lead valve	Soupape	Valvula
11	592-15011-00		1	Platte	Retainer plate	Plaque	Chapa
12	011-90499-80		1	Bolzen M4x10 mm	Socket head bolt	Goujon	Perno
13	001-17051-60		3	Schraube M5x16 mm	Screw assembly	Vis	Tornillo
14	011-90595-10		6	Bolzen M5x14 mm	Socket head bolt	Goujon	Perno
16	004-36051-40		3	Schraube M5x14 mm	Screw assembly	Vis	Tornillo
17	525-55011-00		1	Gebälsegehäuse	Blower housing	Carter turbine	Carter turbina
18	014-00593-50		3	Schraube M5x18 mm	Screw assembly	Vis	Tornillo
19	592-65000-00		1	Ölwanne	Oil casing	Gouttière huile	Cubeta
20	592-65001-00		1	Dichtung	Gasket,casing	Joint	Junta
21	592-65002-00		1	Ölschlauch	Oil tube	Tuyau huile	Tubo de aceite
22	592-65003-00		1	Gewicht	Weight,oil	Poids, huile	Peso
23	592-65006-00		1	Ölfühler	Oil gauge	Jauge, huile	Contacto
24	021-31699-90		1	Dichtung	Gasket	Joint	Junta
25	004-36051-80		4	Schraube M5x18 mm	Screw assembly	Vis	Tornillo
26	065-01099-50		1	Zündkerze	Spark plug	Bougie d'allumage	Bujia
27	592-35038-00		1	Scheibe	Washer	Rondelle	Arandela
28	592-15018-00		2	Ventil	Check valve	Valve	Valvula
31	592-20030-00		1	Kurbelwelle	Crank shaft assy	Vilebrequin	Cigüenal
33	044-01299-60		1	Wellendichtring	Oil seal (L)	Joint spy	Reten
34	044-01099-70		1	Wellendichtring	Oil seal (S)	Joint spy	Reten
35	542-15005-00		1	Sicherung	Clip	Circlip	Anillo
37	592-25009-00		1	Kolben	Piston	Piston	Piston
38	592-20040-00		1	Kolbenring	Piston ring set	Segment de piston	Anillo de piston
41	056-50899-70		2	Kolbenbolzensicherung	Piston pin circlip	Circlip axe de piston	Anillo
42	523-25026-00		1	Kolbenbolzen	Piston pin	Axe de piston	Perno



Bild-Nr. Pos.-No. Pos.-No.	Bestell-Nr. Order-No. No. de Cde Ref.-Nr.	Modell Type Modélo Modelo	Menge Quantity Nombres Cantidad	Vergaser, Ventilsteuerung	Carburetor, exhaust, intake valve	Carburateur ,valve échappement & admission	Carburador, valvula
1	592-60090-00		1	Vergaser enth. (-> 1-21)	Carburetor incl. (-> 1-21)	Carburateur y inclus (-> 1-21)	Carburador incl. (-> 1-21)
2	592-60020-60		1	Körper enth.21	Body assembly-pump incl. 21	Corps ass. y inclus 21	Masa incl. 21
3	523-60461-40		1	Körper	Body assembly-air purge	Corps ass.	Masa
4	523-60460-50		1	Abdeckung	Cover-primer pump	Couverture	Cubierta
5	524-60011-50		1	Pumpe-Primer	Pump-primer	Pompe-Primer	Primer
6	592-60080-10		1	Membran	Diaphragm assy-metering	Membrane	Membrana
7	523-60460-40		1	Dichtung	Gasket-metering diaphragm	Joint	Junta
8	524-60010-40		1	Membran	Diaphragm-pump	Membrane	Membrana-Bomba
9	592-60020-40		1	Dichtung	Gasket-pump	Joint	Junta
10	519-60020-20		1	Düse	jet	Buse	Tobera
11	524-60010-10		1	O-Ring	O-ring	Joint torique	Anillo
12	531-60051-20		1	Ring	Ring	Bague	Anillo
13	523-60180-40		1	Drehzapfen	Swivel	Pivot	Gorron
15	520-60080-30		2	Schraube	Screw-throttle collar	Vis	Tornillo
17	523-60461-10		4	Schraube	Screw-Pump cover	Vis	Tornillo
18	592-60020-20		1	Feder	Spring-pump	Ressort	Resorte
19	542-60050-30		1	Scheibe	Washer	Rondelle	Arandela
21	501-60040-10		1	Einlass-Sieb <-)	Screen-inlet <-)	Tamis <-)	Tamiz <-)
29	592-30050-01		1	Isolierung enth. (-> 29-31)	Insulator compl incl. (-> 29-31)	Isolément cpl. y inclus (-> 29-31)	Aislamiento incl. (-> 29-31)
30	017-00599-80		2	Mutter M5	Nut	Ecrou	Tuerca
31	002-27060-00		2	Mutter M6 <-)	Nut <-)	Ecrou <-)	Tuerca <-)
33	592-35018-01		1	Dichtung	Gasket,insulator	Joint	Junta
34	592-35040-00		1	Dichtung	Gasket,carburetor	Joint	Junta
35	592-35020-00		1	Isolierung	Insulator,carburetor	Isolement	Aislamiento
36	004-36051-80		2	Schraube M5x18 mm	Screw assembly	Vis	Tornillo
37	014-90699-60		1	Schraube	Adjust screw	Vis	Tornillo
38	014-00593-70		1	Schraube M5x12 mm	Screw assembly	Vis	Tornillo
41	592-15014-00		2	Zwischenstück	Spacer	Entretoise	Distanciador
42	592-35000-01		2	Nockenstößel	Cam lifter	Poussoir	Gorron
43	593-30030-00		1	Nockengetriebe	Camgear assy	Rouage à cames	Rueda dentada
44	592-35005-01		1	Welle 5x21.8 mm	Shaft, camgear	Arbre, rouage à cames	Arbol
45	592-35006-00		1	Welle 4x15.8 mm	Shaft, cam lifter	Arbre, poussoir	Arbol
46	592-35007-00		2	Stange	Push rod	Barre	Barra
50	592-30020-00		2	Arm	Rocker arm assy	Bras	Brazo
54	592-35011-01		1	Welle 4x28.8 mm	Rocker shaft	Arbre	Arbol
55	592-35012-00		2	Ventilfeder	Valve spring	Ressort soupape	Resorte
56	592-35013-00		2	Feder	Spring retainer	Rondelle ressort	Resorte
57	592-35014-00		1	Auslassventil	Exhaust valve	Valve d'échappement	Valvula
58	592-35015-00		1	Einlassventil	Intake valve	Valve d'admission	Valvula

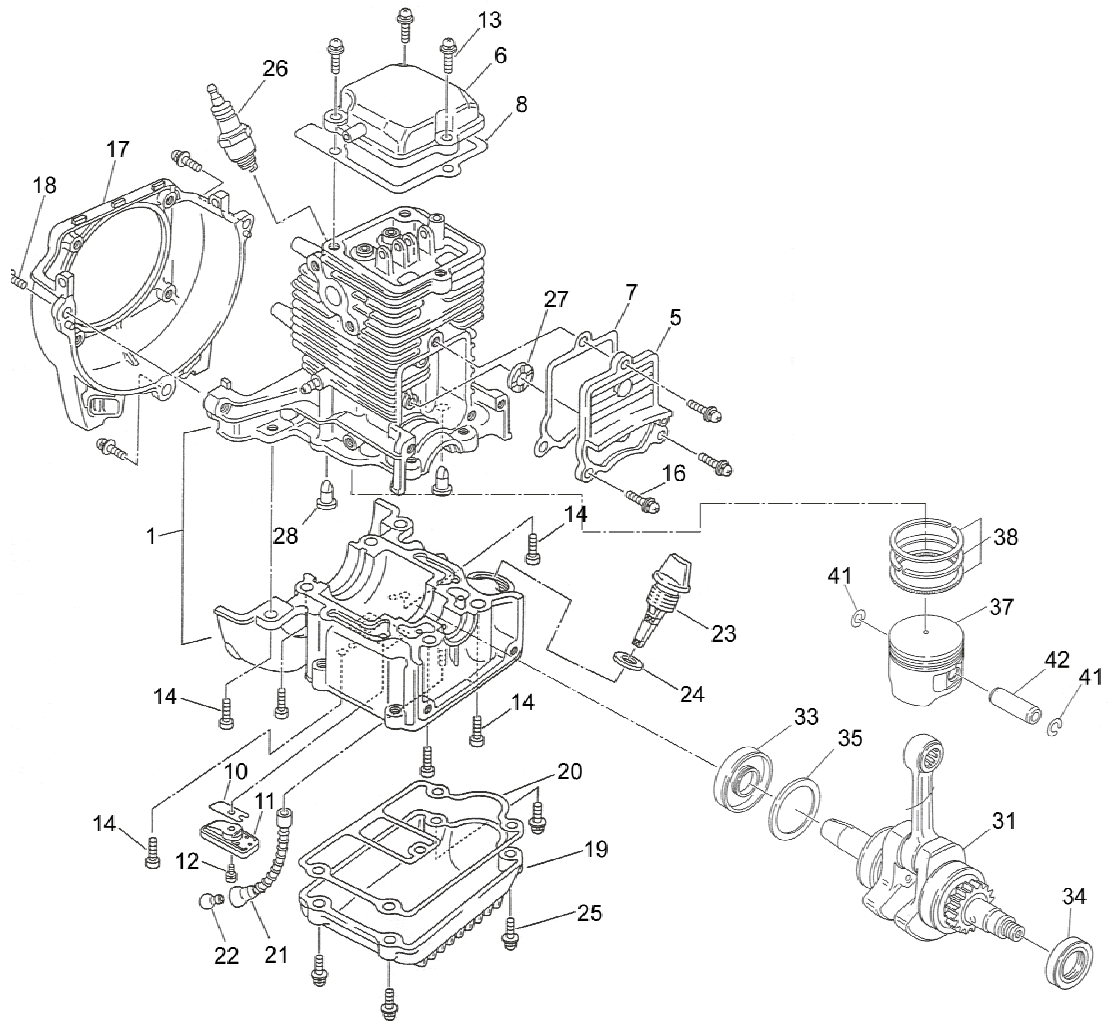

Bild-Nr. Pos.-No. Pos.-No. Pos.-No.	Bestell-Nr. Order-No. No. de Cde Ref.-Nr.	Modell Type Modelo Modelo	Menge Quantity Nombres Cantidad	Starter, Tankhalter, Kraftstofftank	Recoil starter, tank guard, fuel tank	Lanceur, protection réservoir, réservoir d'essence	Arranque, deposito de gasolina
1	592-50010-02		1	Starter enth. (-> 1-10)	Cover starter assy incl. (-> 1-10)	Lanceur, cpl. y inclus (-> 1-10)	Arranque incl. (-> 1-10)
2	592-50010-30		1	Seilrolle	Rope pulley	Poulie de corde	Rollo
3	519-50020-60		1	Schraube	Set screw	Vis	Tornillo
4	521-50020-30		1	Spiralfeder 4x0.4 mm	Spiral spring	Ressort spiral	Resorte
5	519-50021-10		1	Bundring	collar	Collet	Manguito
6	519-50021-00		1	Arm 1,4 mm	Swing arm	Bras	Brazo
8	592-50010-50		1	Starterseil 2,8 mm	Starter rope	Corde de lanceur	Cuerda de arranque
9	522-50040-20		1	Starterknopf	Starter knob	Poignée lanceur	Boton
10	519-55000-00		1	Kulisse <-)	Template <-)	Coulisse <-)	Roldana <-)
11	004-36042-53		2	Schraube M4x25 mm	Screw assembly	Vis	Tornillo
12	023-00499-40		2	Distanzstück	spacer	Entretoise	Espaciador
13	592-95008-00		1	Tankschutz	Tank guard	Protection réservoir	Proteccion
14	004-35051-00		2	Schraube M5x10 mm	Screw assembly	Vis	Tornillo
22	592-65004-00		1	Kraftstofftank	Fuel tank	Réservoir d'essence	Deposito
23	592-60030-00		1	Schlauch	Tube	Tuyau	Tubo
27	523-65039-00		1	Filter	Filter	Filtre	Filtro
28	056-10599-90		1	Schlauchschelle	Hose clamp	Collier, tuyau	Abrazadera
29	592-60170-00		1	Tankdeckel	Fuel tank cap, assy	Bouchon réservoir	Tapa
34	503-65002-00-1		1	Platte	Plate	Plaque	Chapa
35	503-65003-00-1		1	Platte	Plate	Plaque	Chapa
36	519-65003-01		1	Dämpfer	Damper	Amortiseur	Amortiguacion

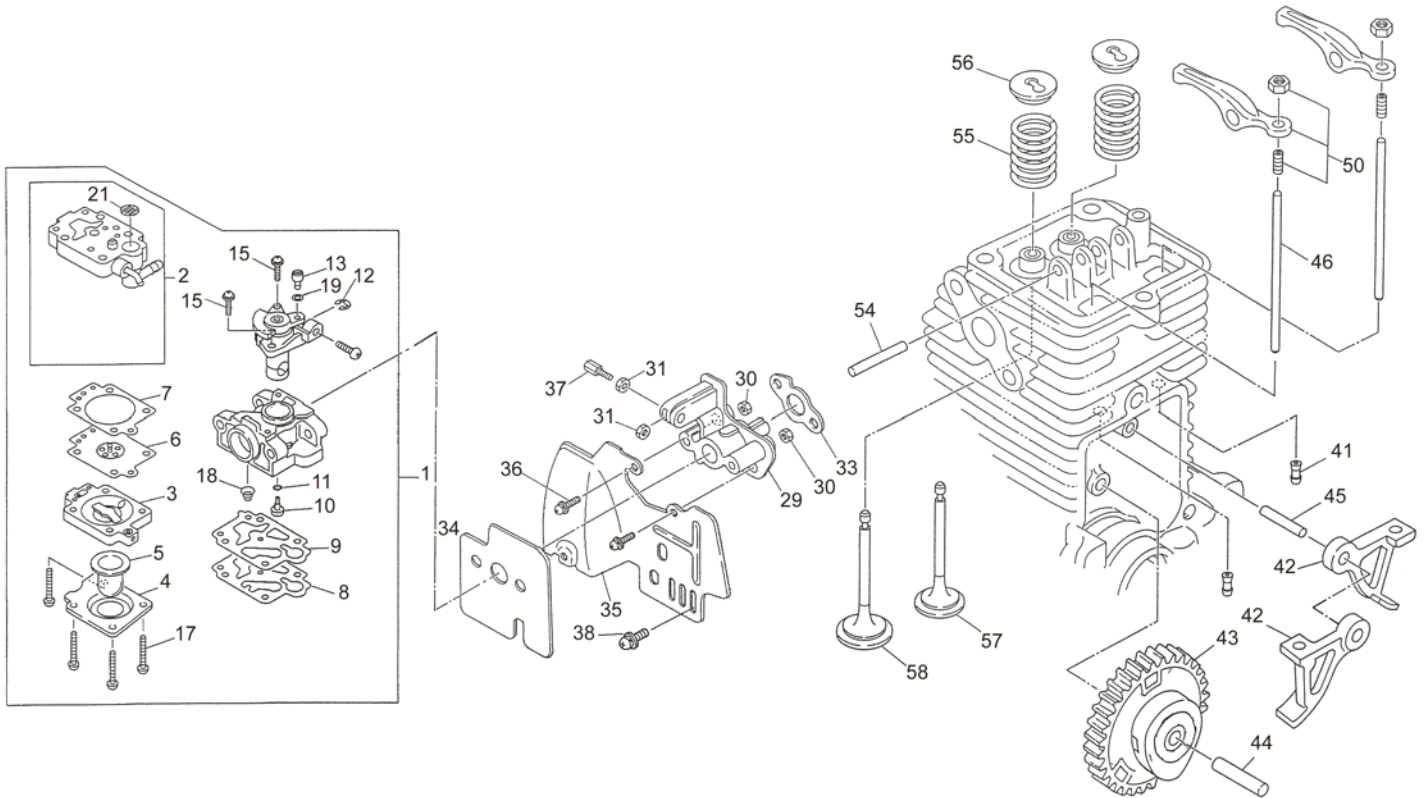

Bild-Nr. Pos.-No. Pos.-No.	Bestell-Nr. Order-No. No. de Cde Ref.-Nr.	Modell Type Modélo Modelo	Menge Quantity Nombres Cantidad	Luftfilter, Auspuff	Air cleaner, exhaust	Filtre à air, échappement	Filtro de aire, escape
1	592-15009-00		1	Leitung 8x4x150 mm	Pipe, breather	Tube	Tuberia
2	593-30010-00		1	Abdeckung enth. (-> 2-12)	Plate, cover assy incl. (-> 2-12)	Carter de filtre à air y inclus (-> 2-12)	Chapa incl. (-> 2-12)
4	531-65007-01		1	Ventil	Check valve	Soupape	Valvula
5	592-35024-00		1	Ventil	Check valve(1)	Soupape	Valvula
6	592-35025-00		1	Platte	Plate, check valve	Plaque	Chapa
7	593-35016-00		1	Platte	Plate, separator	Plaque	Chapa
8	592-35022-00-1		1	Chokehebel	Choke lever	Levier choke	Palanca
10	592-35035-00		1	Dichtung	Gasket, separator	Joint	Junta
11	024-01399-70		1	O-Ring	O-ring	Joint torique	Anillo
12	024-01599-90		1	O-Ring ->)	O-ring ->)	Joint torique ->)	Anillo ->)
13	593-35012-00		1	Luftfilterelement	Element, air cleaner	Élément filtre à air	Elemento filtro
14	592-35023-01		1	Chokeplatte	Choke plate	Clapet	Chapa
15	592-35026-00		1	Schelle	Clamp	Collier de serrage	Chapa
16	021-30699-90		1	Dichtung	Gasket	Joint	Junta
17	593-35008-00		1	Filterabdeckung	Air filter cover	Couvercle de filtre à air	Cubierta
18	592-35030-01		1	Leitung 7x3x60 mm	Pipe	Tube	Tuberia
19	014-00594-80		1	Schraube M5x14 mm	Screw	Vis	Tornillo
21	592-35031-00		2	Schraube M5x68 mm	Screw	Vis	Tornillo
22	056-10800-10		1	Schlauchschelle	Hose clamp	Collier, tuyau	Abrazadera
31	592-30010-00-1		1	Auspuff	Exhaust	Echappement	Escape
32	592-35016-01		1	Auspuffdichtung	Gasket, exhaust	Joint, échappement	Junta
33	592-35034-00		1	Abdeckung	Cover, exhaust	Couvercle	Cubierta
34	011-90595-20		2	Bolzen M5x40 mm	Socket head bolt	Goujon	Perno
35	014-00599-62		1	Schraube M5x5 mm	Screw	Vis	Tornillo
36	592-30080-10		1	Funkenschutz	Spark arrester	Pare-étincelles	Proteccion de chispas

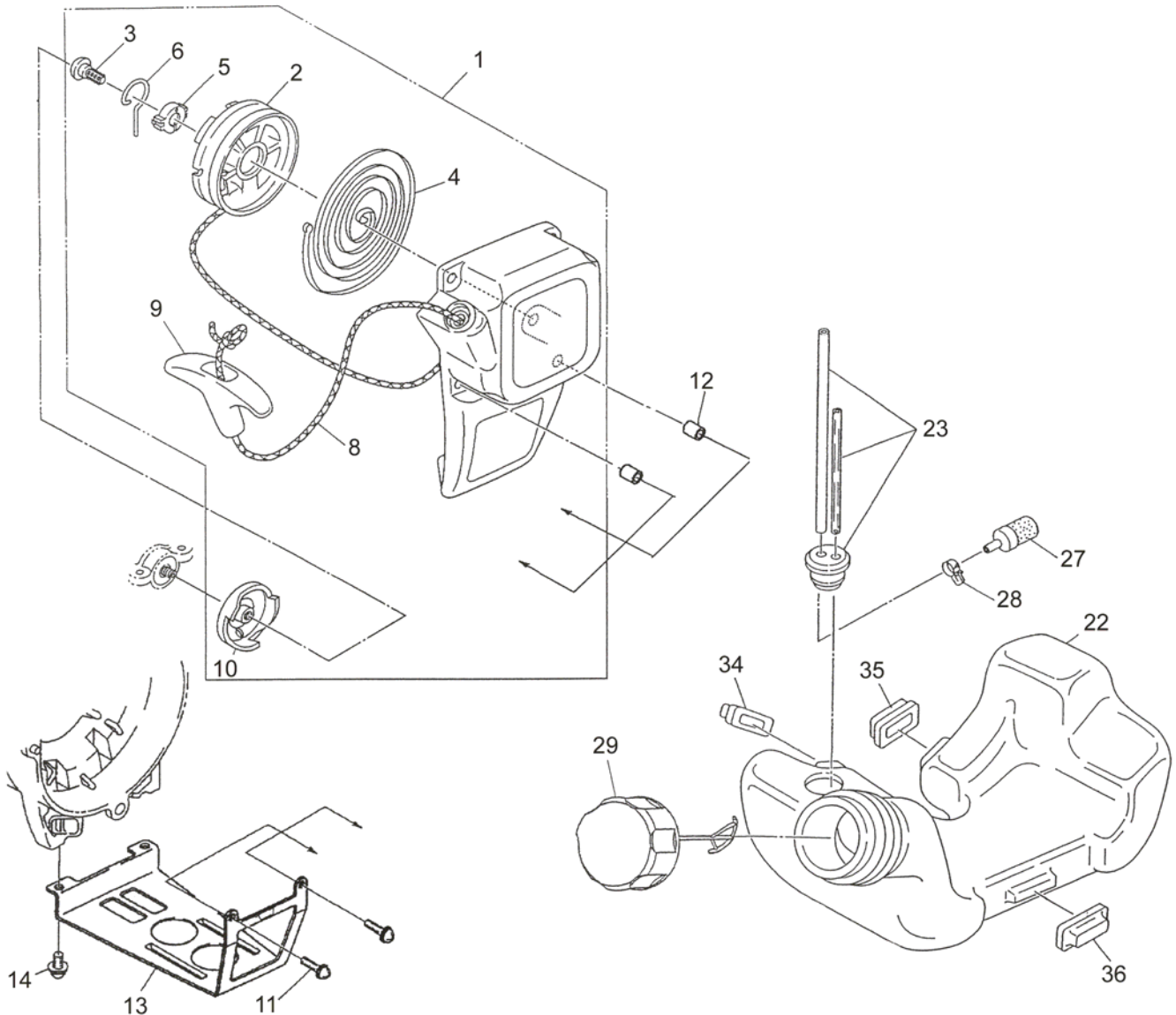

Bild-Nr. Pos.-No. Pos.-No. Pos.-No.	Bestell-Nr. Order-No. No. de Cde Ref.-Nr.	Modell Type Modelo Modelo	Menge Quantity Nombres Cantidad	Lüfterrad, Zündmodul, Kupplung	Flywheel, coil, clutch	Turbine, bobine, embrayage	Turbina, bobina, embrague
1	592-85000-00		2	Kupplungsschuh	Clutch shoe	Coussinet d'embrayage	Patin
2	592-85001-00		1	Feder	Spring	Ressort	Resorte
3	592-85002-00		2	Kupplungsbolzen	Clutch bolt	Goujon, embrayage	Perno
4	592-85003-00		2	Scheibe	Washer	Rondelle	Arandela
5	35 00 422		1	Kupplungsglocke	clutch drum	cloche d'embrayage	campana de embrague
6	00 50 198		1	Kugellager	ball bearing	roulement à bille	cojinete de bolas
7	00 55 106		1	Sicherungsring	circlip	arrêt axe de piston	anillo de seguridad
8	20 11 809		1	Flanschgehäuse	flange housing	carter bride	presilla
9	00 18 349		4	Zylinderschraube M6x30 mm	screw	vis	tornillo
10	00 55 136		1	Sicherungsring	circlip	arrêt axe de piston	anillo de seguridad
12	592-70010-10		1	Zündspule	Ignition coil	Bobine d'allumage	Bobina
13	592-70010-20		1	Lüfterrad	Flywheel	Turbine	Rueda magnetico
14	592-75001-00		1	Zündkerzenstecker	Spark, plug cap	Capuchon bougie	Tapa
15	065-40099-51		1	Kontaktfeder	Spring, plug cap	Ressort	Tapa
16	592-70030-00		1	Kabel	Cable compl	Câble	Alambre
17	525-70180-02		1	Kabel	Cable compl	Câble	Alambre
18	013-00699-40		1	Bolzen M6x16 mm	Bolt assembly	Goujon	Perno
20	014-00499-20		2	Schraube M4x20 mm	Screw	Vis	Tornillo
21	525-75003-00		2	Ring	Grommet	Collier	Anillo

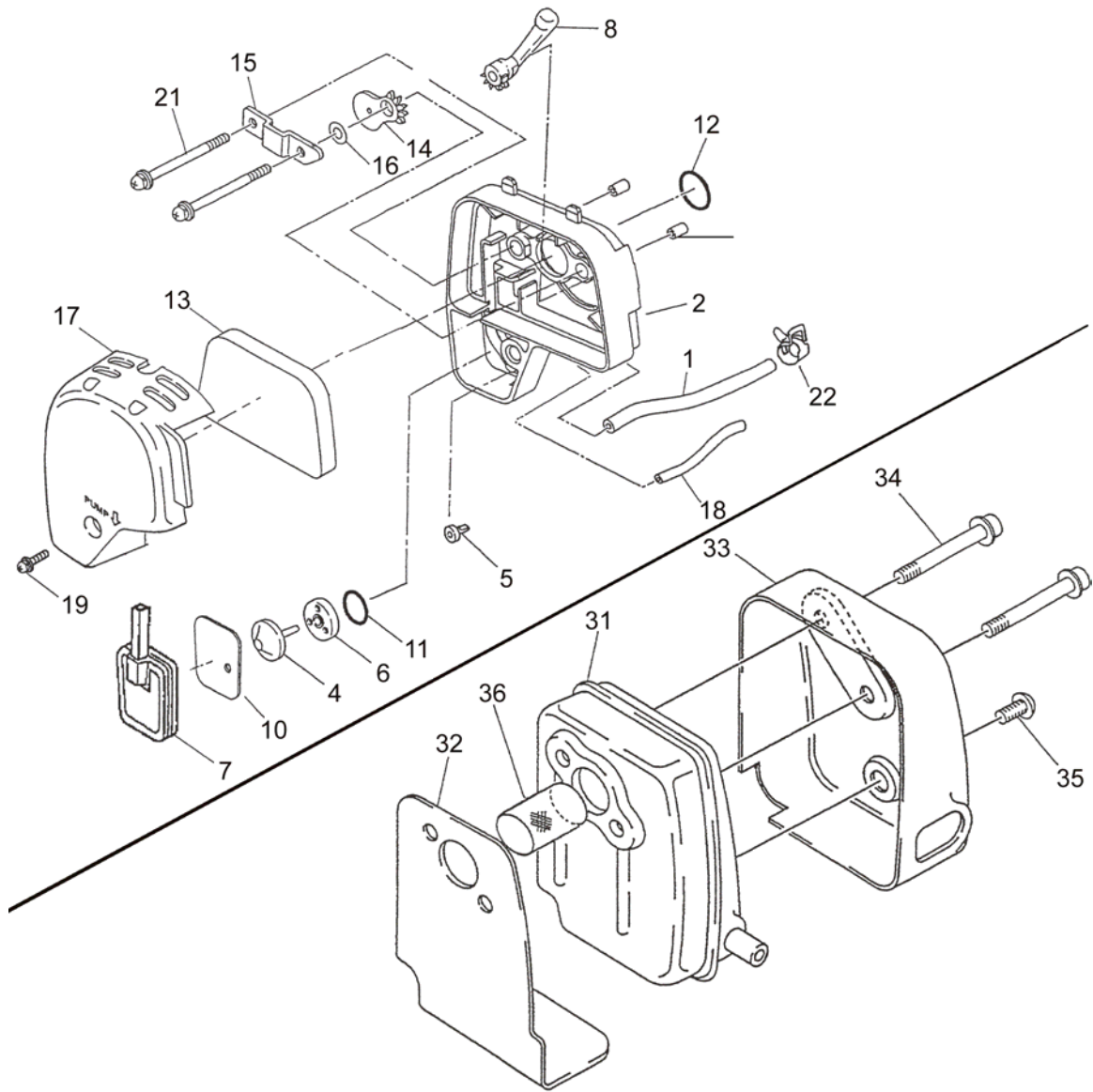

Bild-Nr. Pos.-No. Pos.-No.	Bestell-Nr. Order-No. No. de Cde Ref.-Nr.	Modell Type Modélo Modelo	Menge Quantity Nombres Cantidad	Zylinderabdeckung	Cover cylinder	Capôt cylindre	Cubierta
1	592-55006-00		1	Zylinderabdeckung	Cover cylinder	Capot	Cubierta
2	014-00593-70		2	Schraube M5x12 mm	Screw	Vis	Tornillo
3	014-00497-70		2	Schraube M4x16 mm	Screw	Vis	Tornillo
4	592-75000-00		1	Zündkerzenabdeckung	Spark plug cover	Capuchon de bougie	Tapa de bujia

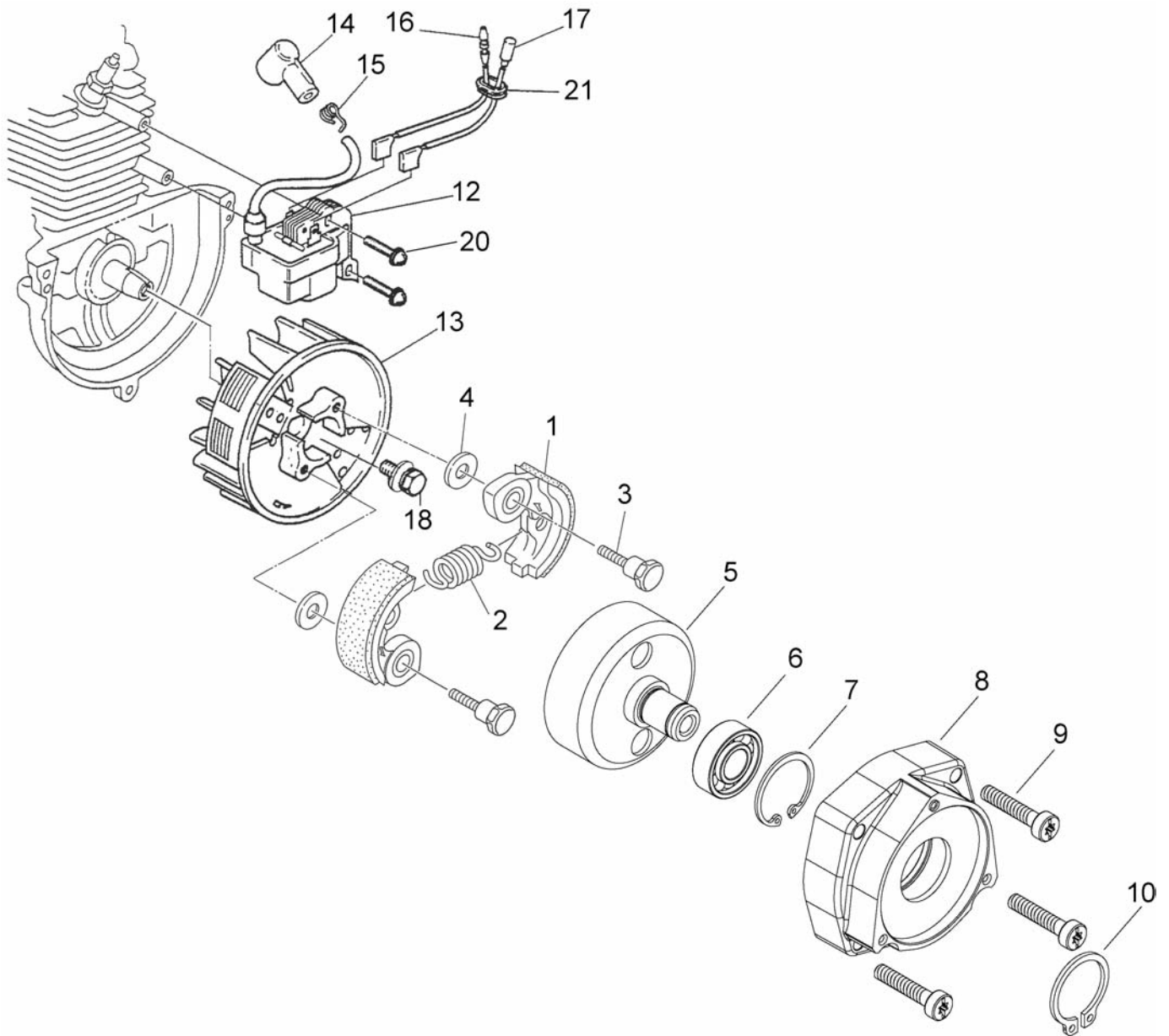

Bild-Nr. Pos.-No. Pos.-No.	Bestell-Nr. Order-No. Ref.-Nr.	Modell Type Modelo	Menge Quantity Nombres Cantidad	Schaftrohr, Schutz, Schaftrohr- anschlussstutzen	Shaft, protection	Tube de transmission, protège lame	Tubo, proteccion
1	00 20 223		1	Sechskantmutter M10x1,25 mm	nut	écrou	tuerca
2	00 72 169		1	Tellerfeder 10,2x23x1,25 mm	spring washer	rondelle ressort	resorte
3	30 31 998		1	Druckscheibe	washer	rondelle	disco
4	30 31 999		1	Druckstück	pressure part	pièce de pression	pieza de presion
5	00 18 335		3	Zylinderschraube M5x12 mm	screw	vis	tornillo
6	20 74 998		1	Wickelschutz	anti-clogging device	protecteur d'enroulement	protec. de arrollamiento
7	30 00 220		1	Getriebe, Mini Gears enth. (-> 7-16	gear incl. (-> 7-16	engrenage y inclus (-> 7-16	engranaje incl. (-> 7-16
8	06 10 438		1	Wellendichtring 17x32x8 mm	oil seal	joint spil	retén
9	06 10 436		1	Distanzring	spacer	bague à distance	anillo distanciador
10	00 61 150		1	Dichtungsring 8x14x1,5 mm	gasket	joint plat	empaque
11	00 12 140		1	Sechskantschraube M8x10 mm	screw	vis	tornillo
12	06 10 432		1	Zylinderschraube M5x8 mm	screw	vis	tornillo
---	00 83 180		100g	Getriebefett	grease	graisse	grasa
14	00 12 194		2	Sechskantschraube M5x40 mm	screw	vis	tornillo
15	00 30 108		2	Scheibe 5,3 mm	washer	rondelle	arandela
16	00 28 110		2	Sechskantmutter M5 <-)	nut <-)	écrou <-)	tuerca <-)
17	60 35 978		1	Antriebswelle	drive shaft	arbre	arbol
18	63 00 251		1	Schaftrohr 24x1x1500 mm enth. (-> 18-19	shaft tube incl. (-> 18-19	tube y inclus (-> 18-19	tubo incl. (-> 18-19
19	00 55 286		1	Zackenring 22 <-)	toothed ring <-)	bague dentée <-)	anillo dentada <-)
20	00 18 338		2	Zylinderschraube M5x25 mm	screw	vis	tornillo
21*	00 18 378		2	Zylinderschraube M5x55 mm	screw	vis	tornillo
22*	60 74 973		1	Zwischenstück	intermediate piece	pièce intermédiaire	pieza intermedia
23	60 73 618		1	Schutz	protection	protection	proteccion
24*	00 18 274		2	Linsenschraube M5x16 mm	screw	vis	tornillo
25*	60 43 373		1	Fadenbegrenzungsmesser	knife	couteau	cuchilla
26	00 21 241		2	Vierkantmutter M5	nut	écrou	tuerca
27	60 43 438		2	Schelle, 24 mm	clamp	collier de serrage	abrazadera
30	20 74 972		1	Klemmstück	clamp	collier	abrazadera
31	00 18 338		1	Zylinderschraube M5x25 mm	screw	vis	tornillo
32	00 18 337		3	Zylinderschraube M5x20 mm	screw	vis	tornillo
33	00 18 405		1	Zylinderschraube M5x14,5 mm	screw	vis	tornillo
34	00 21 241		1	Vierkantmutter M5	nut	écrou	tuerca
35	20 74 952		1	Distanzring	ring	joint	anillo
36	00 66 457		1	Schelle	clamp	collier de serrage	abrazadera

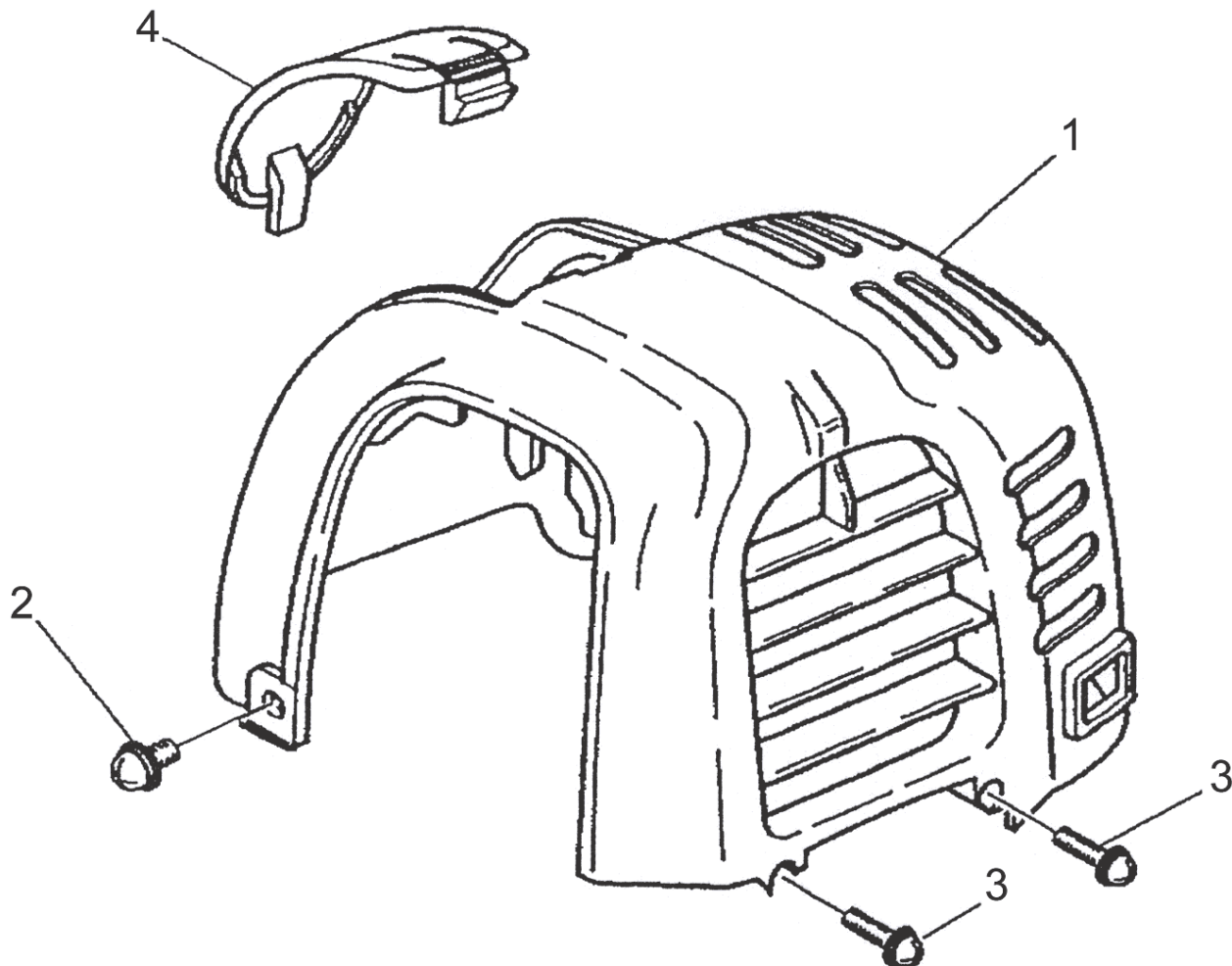

Bild-Nr. Pos.-No. Pos.-No.	Bestell-Nr. Order-No. No. de Cde Ref.-Nr.	Modell Type Modélo Modelo	Menge Quantity Nombres Cantidad	Gasbetätigung, Griff 106LR	Throttle control, handle 106LR	Levier régulateur, guidon 106LR	Acelerador de gas, empuñadura 106LR
1	60 63 331	106LR	1	Griff	Handle	Guidon	Empuñadura
2	68 00 306	106LR	1	Gasgriff enth. (->2-4	throttle lever incl. (-> 2-4	levier de gaz y inclus (-> 2-4	palanca gas incl. (-> 2-4
3	00 10 182	106LR	2	Zylinderschraube. M5x20 mm	screw	vis	tornillo
4	00 21 257	106LR	2	Vierkantmutter M5 <-)	nut <-)	écrou <-)	tuerca <-)
6	28 00 580	106LR	1	Bowdenzug Gas	Throttle cable	Câble des gaz	Cable bowden
7	00 84 879	106LR	1	Kabel Masse/Kurzschluss	Ground cable	Câble de masse	Cable de masa
8	00 64 415 27	106LR	235 mm	Schlauch 8,5 mm	Hose	Tuyau	Tubo
9	20 73 119	106LR	1	Loopgriff	loop handle	guidon-loop	languero
10	00 18 349	106LR	1	Zylinderschraube M6x30 mm	screw	vis	tornillo
11	00 30 125	106LR	2	Scheibe 6,4 mm	Washer	Rondelle	Arandela
12	00 28 111	106LR	1	Mutter Sechskant M6	nut	écrou	tuerca
13	28 00 140	106LR	1	Abstandhalter enth. (->13,14	stop plate incl. (-> 13,14	butée y inclus (-> 13,14	tope incl. (-> 13,14
14	20 63 143	106LR	1	Kappe <-)	cover <-)	capuchon <-)	caperuza <-)
15	00 44 286	106LR	1	Abdeckklammer	clamp	collier	abrazader

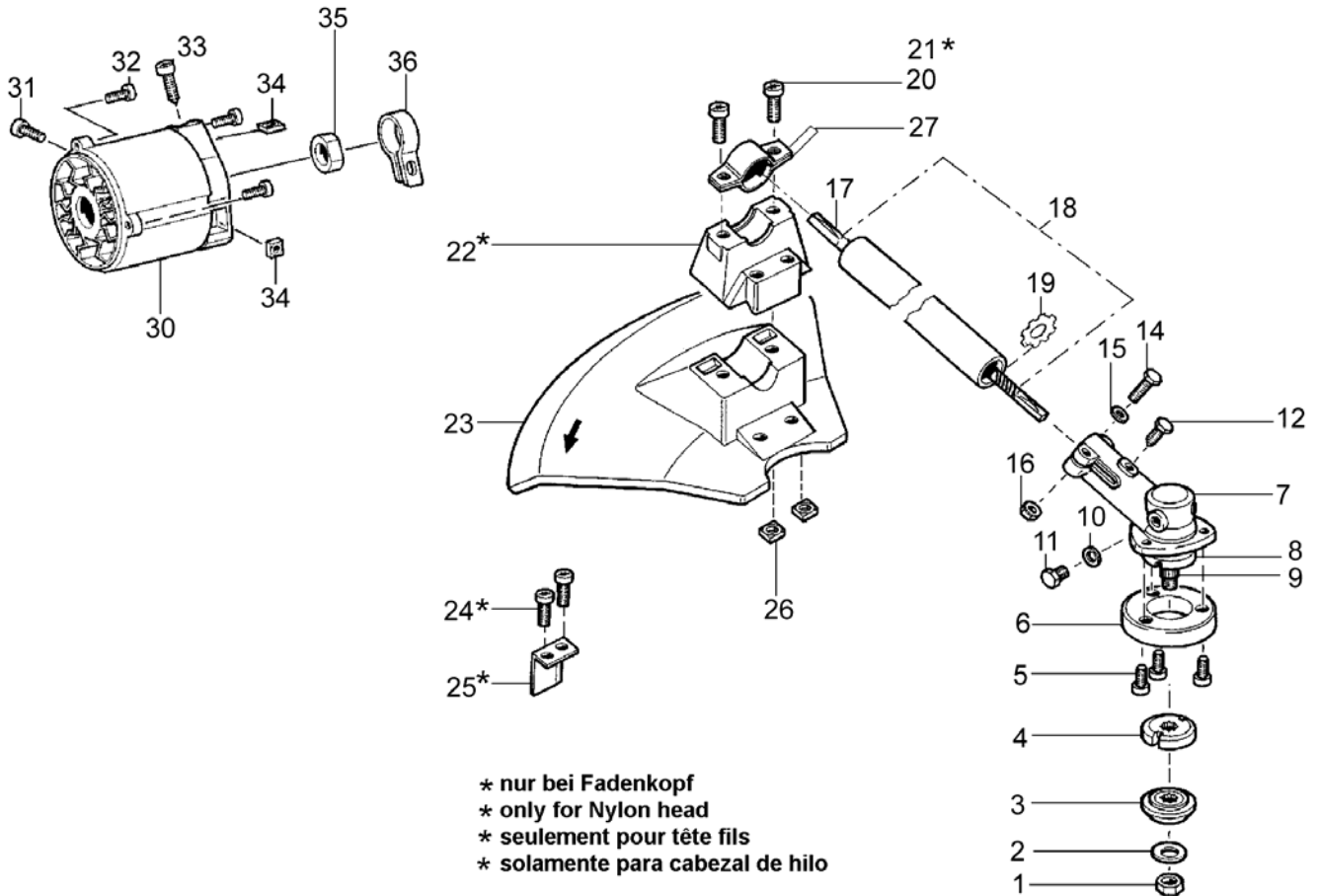

Bild-Nr. Pos.-No. Pos.-No.	Bestell-Nr. Order-No. No. de Cde Ref.-Nr.	Modell Type Modélo Modelo	Menge Quantity Nombres Cantidad	Griff, Gasbetätigung 106BR	Double handle, throttle control 106BR	Poignée guidon, levier régulateur 106BR	Tubo, acelerador de gas 106BR
1	60 12 843	106BR	1	Klemmhalter, 24 mm	circlip	reteneur	retenedor
2	68 00 264	106BR	1	Gurtbefestigung	strap holder	porte-bretelle	hebilla para correa
3	00 18 337	106BR	2	Zylinderschraube M5x20 mm	screw	vis	tornillo
4	60 12 836	106BR	1	Klemmschale, für 22 mm	handlebar clamp	plaque de serrage guidon	abrazadera
5	60 12 837	106BR	1	Klemmschale, für 22 mm	handlebar clamp	plaque de serrage guidon	abrazadera
6	00 30 128	106BR	1	Scheibe 8,4 mm	washer	rondelle	arandela
7	00 12 376	106BR	1	Sechskantschraube M8x65 mm	screw	vis	tornillo
8	00 18 337	106BR	2	Zylinderschraube M5x20 mm	screw	vis	tornillo
9	60 35 370	106BR	1	Bike-Griffrohr 22x1,5 mm	handlebar	étrier de maintien	tubo de palanca
10	00 18 364	106BR	1	Zylinderschraube M5x32 mm	screw	vis	tornillo
11	60 73 567	106BR	1	Griffhälfte für Ø 22 mm	grip half	poignée extérieure	cascara
12	00 18 356	106BR	2	Linsenschraube 4x20 mm	screw	vis	tornillo
13	60 73 568	106BR	1	Griffhälfte für Ø 22 mm	grip half	poignée extérieure	cascara
14	00 20 131	106BR	1	Sechskantmutter M5	nut	écrou	tuerca
15	68 00 131	106BR	1	Gasgriff, komplett enth. (-> 15-33)	throttle grip, compl. incl. (-> 15-33)	poignée acc., compl. y inclus (-> 15-33)	acelerador incl. (-> 15-33)
16	00 18 356	106BR	3	Linsenschraube 4x20 mm	screw	vis	tornillo
17	00 73 389	106BR	1	Kontaktfeder	contact spring	ressort de contact	resorte
18	00 73 388	106BR	1	Kontaktfeder	contact spring	ressort de contact	resorte
19	00 73 387	106BR	1	Schenkelfeder 1,3x6, Schieber	spring	ressort d'interrupteur	muelle
20	00 73 386	106BR	1	Schenkelfeder 1x8, Gashebel	spring	ressort d'interrupteur	muelle
21	60 73 573	106BR	1	Gashebel	throttle lever	levier de gaz	palanca de gas
22	00 35 158	106BR	1	Sicherungsscheibe 4,5x0,3 mm	washer	rondelle	arandela
23	60 73 572	106BR	1	Schieber	slide	tiroir	valvula
24	60 73 571	106BR	1	Sicherungshebel	safety lever	levier de sécurité	palanca
25	60 73 569	106BR	1	Griffhälfte für 22 mm	grip half	poignée extérieure	cascara
26	60 73 570	106BR	1	Griffhälfte für 22 mm	grip half	poignée extérieure	cascara
27	00 18 364	106BR	1	Zylinderschraube M5x32 mm	screw	vis	tornillo
28	00 20 131	106BR	1	Sechskantmutter M5	nut	écrou	tuerca
29	00 84 874	106BR	1	Kabel Masse/Kurzschluss	ground cable	câble masse	cable de masa
30	00 84 875	106BR	1	Kabel Masse/Kurzschluss	ground cable	câble masse	cable de masa
31	28 00 581	106BR	1	Bowdenzug Gas	Throttle cable	Câble des gaz	Cable bowden
32	00 64 415 27	106BR	860 mm	Schlauch 8,5 mm	Hose	Tuyau	Tubo
33	50 74 100	106BR	1	Bowdenzughalter, 22 mm (->)	bowden cable support (->)	collier de serrage (->)	soporte de cable bowden (->)
34	60 74 527	106BR	2	Bowdenzughalter, 24 mm	bowden cable support	collier de serrage	soporte de cable bowden

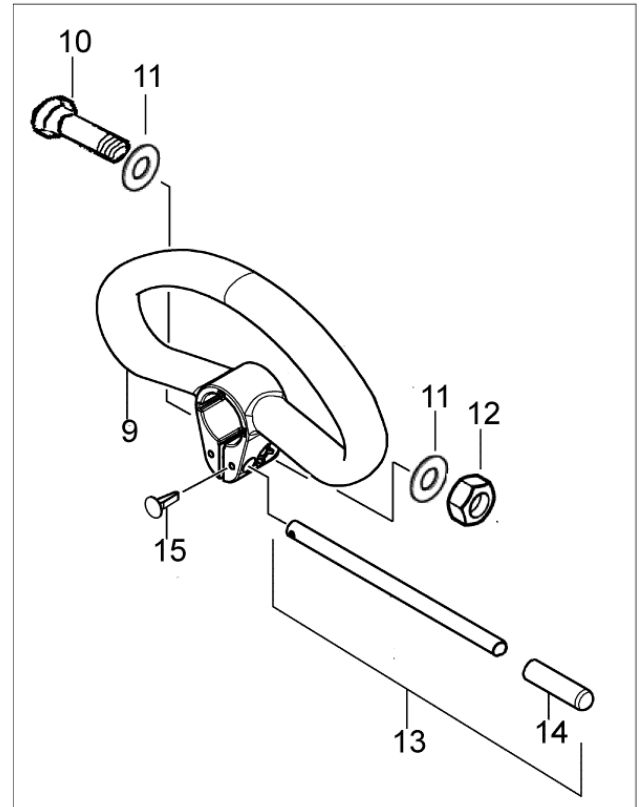
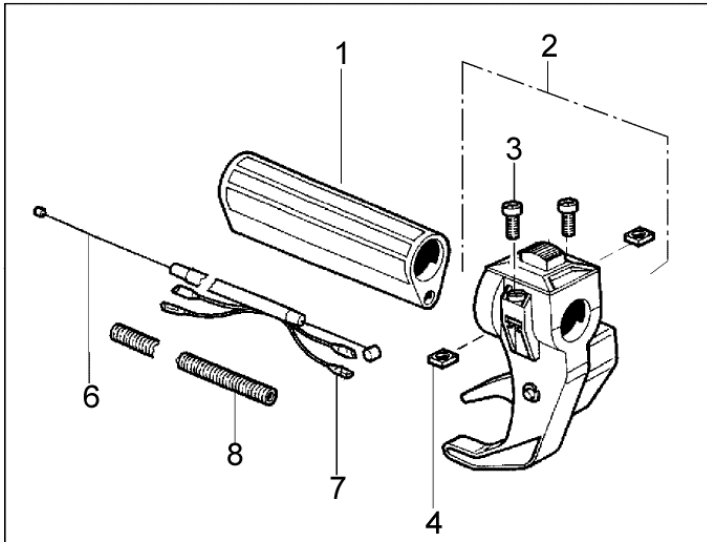

** nicht bei Fadenkopf
 ** not with nylon head
 ** ne pas avec tête fils
 ** no para cabezal de hilo

Bild-Nr. Pos.-No. Pos.-No.	Bestell-Nr. Order-No. No. de Cde Ref.-Nr.	Modell Type Modélo Modelo	Menge Quantity Nombres Cantidad	Werkzeug	Tools	Outillage	Herramientas
1	00 80 494		1	Schraubendreher	screw-driver	tournevis	destornillador
2	00 80 509		1	Kombischlüssel SW19/T25	combi wrench SW19/T25	clef combi SW19/T25	llave combi SW19/T25
3	69 00 691		1	Schutzbrille	safety goggles	lunettes de protection	gafas protectoras
4	00 80 514		1	Montagestift 5 mm	locking pin	goupille de montage	perno
5	69 00 924		1	Tragegurt mit Befestigung	carrying strap	bretelle	cinturon portador
6	69 00 651	106LR	1	Fadenkopf, halbautom.	semi-autom. nylon head	tête fils semi-autom.	cabezal de hilo semi- autom.
9	69 00 948	106BR	1	Grasschneideblatt, 4 Zähne Ø 230 mm	grass cutt. blade 4-T	lame herbe, 4-dents	hoja de corte, 4 dientes
10	60 73 534	106BR	1	Transportschutz	transport protection	protection transport	proteccion transporte
11	30 43 427		1	Lauffeller	disc	rondelle bombée	plato
13	592-90020-00		1	Kombischlüssel Motor	combi wrench engine	clef combi moteur	llave combi motor
14	592-95023-00		1	Gebrauchsanweisung Motor	Instruction manual engine	Instructions d'emploi moteur	Instrucciones de manejo motor

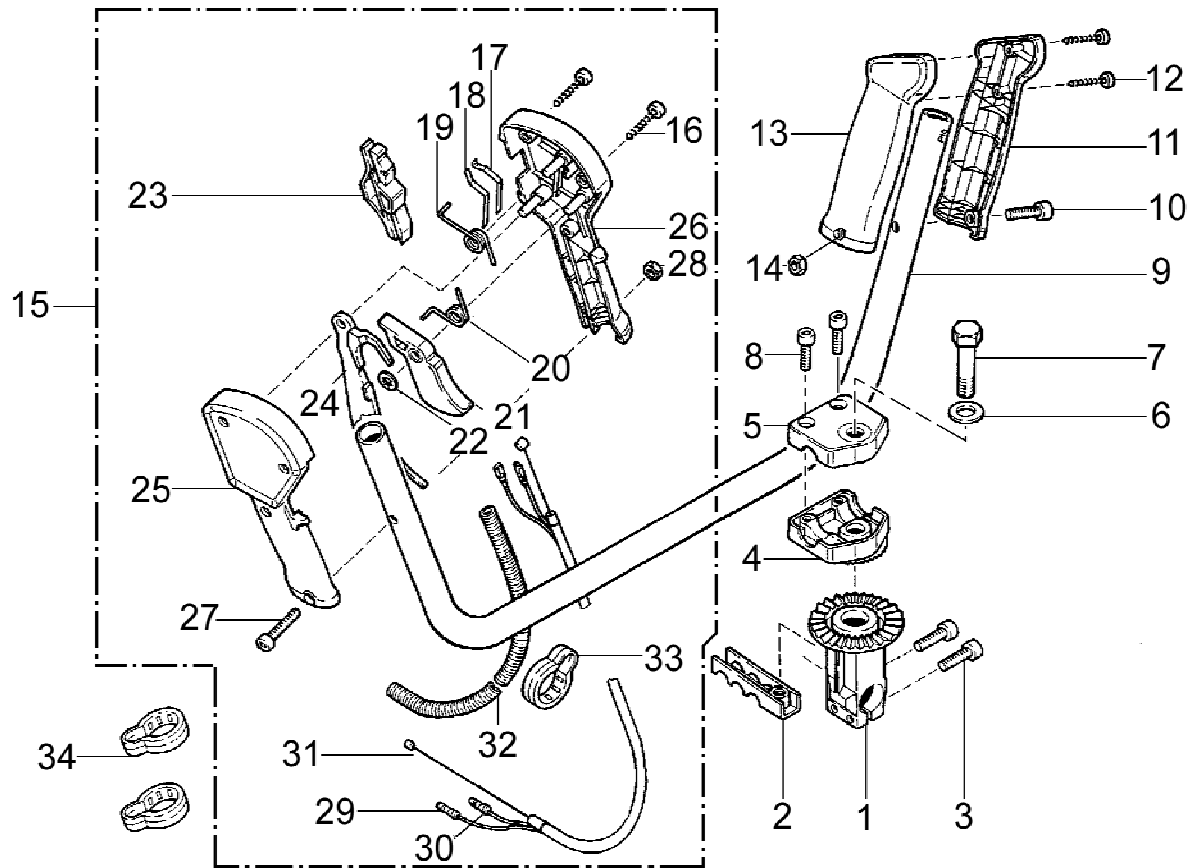
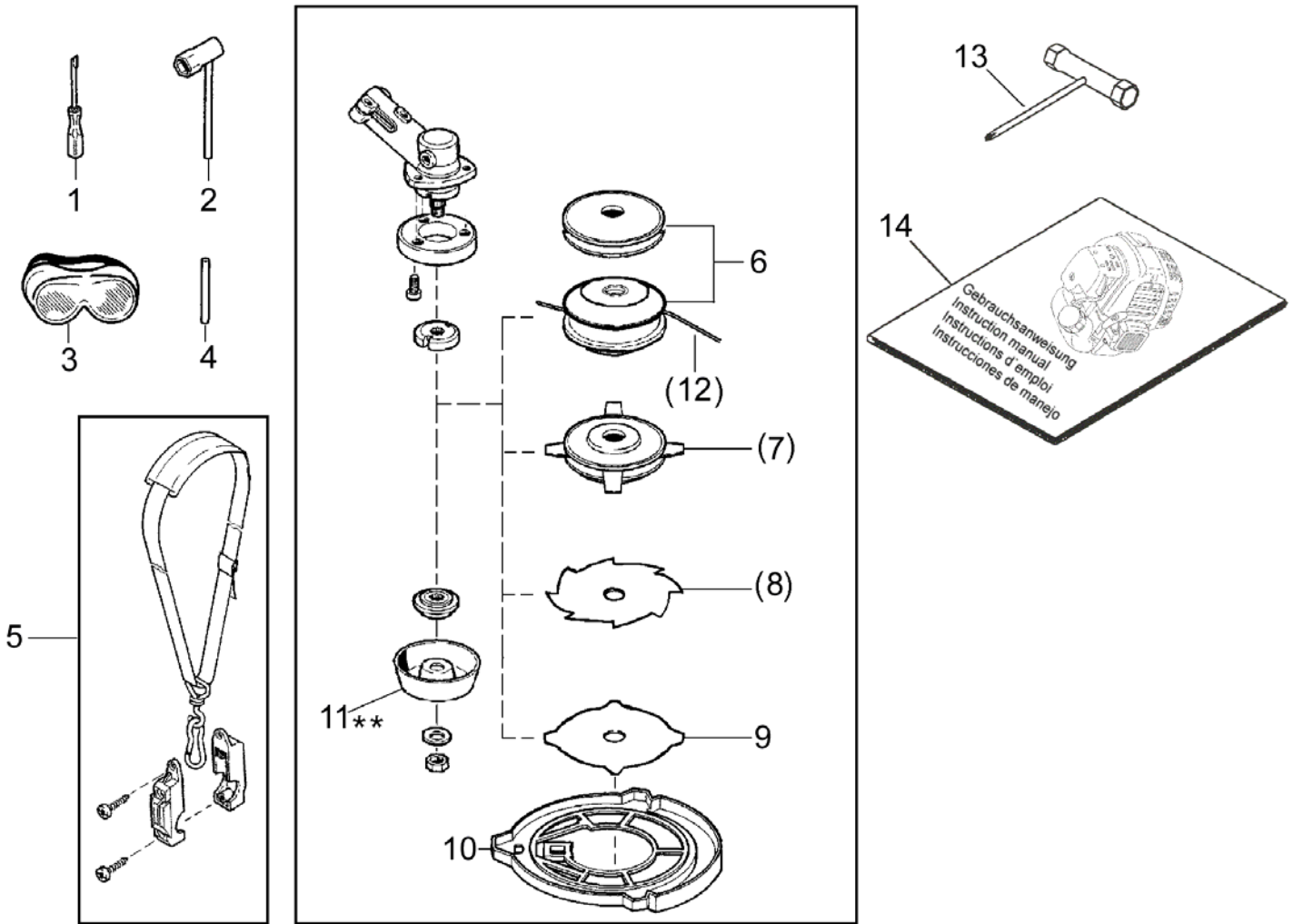
				Zubehör	Accessories	Accesories	Accesorios
(6)	69 00 651		1	Fadenkopf, halbautom.	semi-autom. nylon head	tête fils semi-autom.	cabezal de hilo semi- autom.
(7)	69 00 945		1	Mähsscheibe, Rototrim	Rototrim mowing blade	lame, Rototrim	disco de corte, Rototrim
(8)	69 00 946		1	Grasschneideblatt, 8 Zähne Ø 230 mm	mowing blade, 8-teeth	lame herbe, 8- couteaux	disco de corte, 8-dientes
(9)	69 00 948		1	Grasschneideblatt, 4 Zähne Ø 230 mm	grass cutt. blade 4-T	lame herbe, 4-dents	hoja de corte, 4 dientes
(10)	60 73 534		1	Transportschutz	transport protection	protection transport	proteccion transporte
(12)	69 00 997		15m	Ersatzfaden für Fadenkopf	replacement line	recharge fils	hilo de recambio

Bestell-Nr. Order-No. No. de Cde Ref.-Nr.	Menge Quantity Nombres Cantidad	Seite Page Page Pagina
00 10 182	2	9
00 12 140	1	8
00 12 194	2	8
00 12 376	1	10
00 18 274	2	8
00 18 335	3	8
00 18 337	3	8
00 18 337	2	10
00 18 337	2	10
00 18 338	2	8
00 18 338	1	8
00 18 349	4	6
00 18 349	1	9
00 18 356	2	10
00 18 356	3	10
00 18 364	1	10
00 18 364	1	10
00 18 378	2	8
00 18 405	1	8
00 20 131	1	10
00 20 131	1	10
00 20 223	1	8
00 21 241	2	8
00 21 241	1	8
00 21 257	2	9
00 28 110	2	8
00 28 111	1	9
00 30 108	2	8
00 30 125	2	9
00 30 128	1	10
00 35 158	1	10
00 44 286	1	9
00 50 198	1	6
00 55 106	1	6
00 55 136	1	6
00 55 286	1	8
00 61 150	1	8
00 64 415 27	235 mm	9
00 64 415 27	860 mm	10
00 66 457	1	8
00 72 169	1	8
00 73 386	1	10
00 73 387	1	10
00 73 388	1	10
00 73 389	1	10
00 80 494	1	11
00 80 509	1	11
00 80 514	1	11
00 83 180	100g	8
00 84 874	1	10
00 84 875	1	10
00 84 879	1	9
001-17051-60	3	2
002-27060-00	2	3
004-35051-00	2	4
004-36042-53	2	4
004-36051-40	3	2
004-36051-80	4	2
004-36051-80	2	3

Bestell-Nr. Order-No. No. de Cde Ref.-Nr.	Menge Quantity Nombres Cantidad	Seite Page Page Pagina
011-90499-80	1	2
011-90595-10	6	2
011-90595-20	2	5
013-00699-40	1	6
014-00497-70	2	7
014-00499-20	2	6
014-00593-50	3	2
014-00593-70	1	3
014-00593-70	2	7
014-00594-80	1	5
014-00599-62	1	5
014-90699-60	1	3
017-00599-80	2	3
021-30699-90	1	5
021-31699-90	1	2
023-00499-40	2	4
024-01399-70	1	5
024-01599-90	1	5
044-01099-70	1	2
044-01299-60	1	2
056-10599-90	1	4
056-10800-10	1	5
056-50899-70	2	2
06 10 432	1	8
06 10 436	1	8
06 10 438	1	8
065-01099-50	1	2
065-40099-51	1	6
20 11 809	1	6
20 63 143	1	9
20 73 119	1	9
20 74 952	1	8
20 74 972	1	8
20 74 998	1	8
28 00 140	1	9
28 00 580	1	9
28 00 581	1	10
30 00 220	1	8
30 31 998	1	8
30 31 999	1	8
30 43 427	1	11
35 00 422	1	6
50 74 100	1	10
501-60040-10	1	3
503-65002-00-1	1	4
503-65003-00-1	1	4
519-50020-60	1	4
519-50021-00	1	4
519-50021-10	1	4
519-55000-00	1	4
519-60020-20	1	3
519-65003-01	1	4
520-60080-30	2	3
521-50020-30	1	4
522-50040-20	1	4
523-25026-00	1	2
523-60180-40	1	3
523-60460-40	1	3
523-60460-50	1	3

Bestell-Nr. Order-No. No. de Cde Ref.-Nr.	Menge Quantity Nombres Cantidad	Seite Page Page Pagina
523-60461-10	4	3
523-60461-40	1	3
523-65039-00	1	4
524-60010-10	1	3
524-60010-40	1	3
524-60011-50	1	3
525-55011-00	1	2
525-70180-02	1	6
525-75003-00	2	6
531-60051-20	1	3
531-65007-01	1	5
542-15005-00	1	2
542-60050-30	1	3
592-10040-01	1	2
592-10050-01	1	2
592-15005-02	1	2
592-15007-00	1	2
592-15008-00	1	2
592-15009-00	1	5
592-15010-00	1	2
592-15011-00	1	2
592-15014-00	2	3
592-15018-00	2	2
592-20030-00	1	2
592-20040-00	1	2
592-25009-00	1	2
592-30010-00-1	1	5
592-30020-00	2	3
592-30050-01	1	3
592-30080-10	1	5
592-35000-01	2	3
592-35005-01	1	3
592-35006-00	1	3
592-35007-00	2	3
592-35011-01	1	3
592-35012-00	2	3
592-35013-00	2	3
592-35014-00	1	3
592-35015-00	1	3
592-35016-01	1	5
592-35018-01	1	3
592-35020-00	1	3
592-35022-00-1	1	5
592-35023-01	1	5
592-35024-00	1	5
592-35025-00	1	5
592-35026-00	1	5
592-35030-01	1	5
592-35031-00	2	5
592-35034-00	1	5
592-35035-00	1	5
592-35038-00	1	2
592-35040-00	1	3
592-50010-02	1	4
592-50010-30	1	4
592-50010-50	1	4
592-55006-00	1	7
592-60020-20	1	3
592-60020-40	1	3

Bestell-Nr. Order-No. No. de Cde Ref.-Nr.	Menge Quantity Nombres Cantidad	Seite Page Page Pagina
592-60020-60	1	3
592-60030-00	1	4
592-60080-10	1	3
592-60090-00	1	3
592-60170-00	1	4
592-65000-00	1	2
592-65001-00	1	2
592-65002-00	1	2
592-65003-00	1	2
592-65004-00	1	4
592-65006-00	1	2
592-70010-10	1	6
592-70010-20	1	6
592-70030-00	1	6
592-75000-00	1	7
592-75001-00	1	6
592-85000-00	2	6
592-85001-00	1	6
592-85002-00	2	6
592-85003-00	2	6
592-90020-00	1	11
592-95008-00	1	4
592-95023-00	1	11
593-30010-00	1	5
593-30030-00	1	3
593-35008-00	1	5
593-35012-00	1	5
593-35016-00	1	5
60 12 836	1	10
60 12 837	1	10
60 12 843	1	10
60 35 370	1	10
60 35 978	1	8
60 43 373	1	8
60 43 438	2	8
60 63 331	1	9
60 73 534	1	11
60 73 567	1	10
60 73 568	1	10
60 73 569	1	10
60 73 570	1	10
60 73 571	1	10
60 73 572	1	10
60 73 573	1	10
60 73 618	1	8
60 74 527	2	10
60 74 973	1	8
63 00 251	1	8
68 00 131	1	10
68 00 264	1	10
68 00 306	1	9
69 00 651	1	11
69 00 691	1	11
69 00 924	1	11
69 00 945	1	11
69 00 946	1	11
69 00 948	1	11
69 00 997	15m	11

(D)
Allgemeine Richtlinien für die Bestellung von Original SOLO Ersatzteilen:

Voraussetzung für eine reibungslose Erledigung sind folgende Angaben:

1. Ersatzteil-Bestellnummer
2. Gewünschte Anzahl
3. Typenbezeichnung des Geräts

Diese Ersatzteilliste ist für die Lieferung und Ausstattung von SOLO Erzeugnissen unverbindlich. Im Interesse der technischen Weiterentwicklung bleiben Konstruktionsänderungen vorbehalten.

(GB)
General Directions for Ordering Original SOLO Spare Parts:

For correct and diligent processing of your order, please give the following information:

1. Spare Part number
2. Quantity
3. Model and serial number
4. Shipping instructions

Delivery is made in accordance with our general sales and delivery conditions. This spare parts list is non-committal for us with regard to delivery and layout of SOLO products. In favour of technical improvements, design modifications are subject to change without notice.

(F)
Directives générales pour les commandes de pièces de rechange d'origine SOLO:

Il est indispensable de préciser dans toutes les commandes de pièces:

1. le numéro de référence de la pièce
2. la quantité
3. le type de la machine
4. le mode d'expédition

Les livraisons sont effectuées dans le cadre de nos conditions générales de vente. Toutes modifications réservées.

(E)
Directivas Generales de pedido de la firma SOLO:

Por adelantado de un arreglo sin dificultades necesitamos siguientes indicaciones:

1. Número de repuesto
2. Numero de cantidad
3. Modelo y número de serial
4. Instrucción de Envío

Esta lista de repuestos no es obligatoria para los envíos y/o forma de equipo de los productos SOLO. En el interés del constante desarrollo debemos reservarnos el derecho de cambios.